

# DEVELOPMENT AND ECONOMIC APPLICATION OF KNELSON CONCENTRATORS IN LOW GRADE ALLUVIAL GOLD DEPOSITS

1990



## The AusIMM 1990 Annual Conference **THE MINERAL INDUSTRY IN NEW ZEALAND**

Small Scale Mining  
Alluvial Mining  
Industrial Minerals

Gold Geology and Technology  
Energy - Coal, Oil,  
Natural Gas and Geothermal

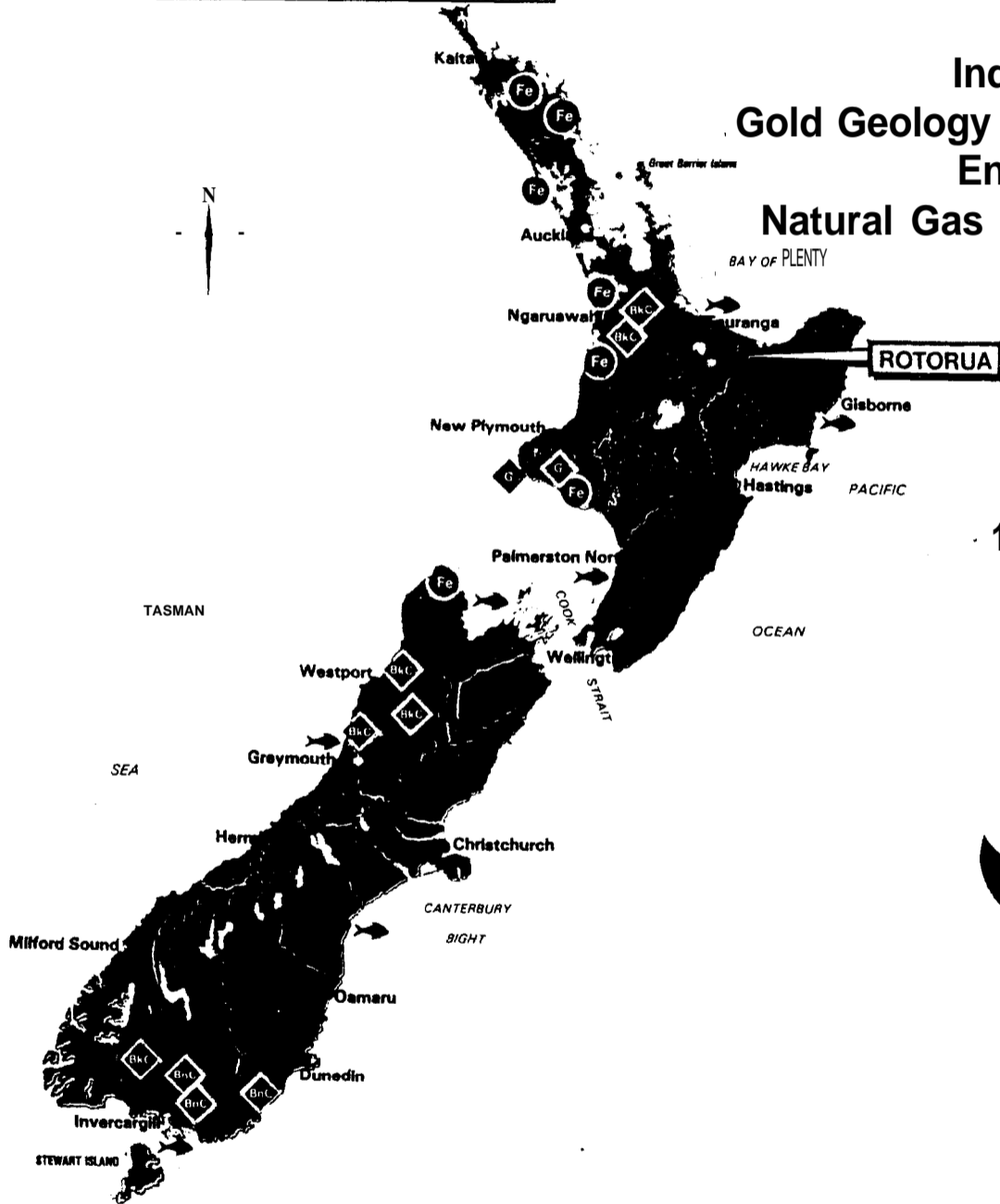

Rotorua  
New Zealand  
18-21 March 1990



# Development and Economic Application of Knelson Concentrators in Low Grade Alluvial Gold Deposits

BYRON KNELSON<sup>1</sup> and RON EDWARDS<sup>2</sup>\*

## ABSTRACT

Greater efficiency of capture of minus 6 mm to fine micron size particles of free gold is achieved with the Knelson concentrator. The development, principles of operation and recent innovations relating this enhanced gravity concentrating device are described by the inventor followed by a description of application and consequent economic benefits in low grade alluvial gold deposits by a large scale user of Knelson Concentrators in the Northern Territory of Australia.

## DEVELOPMENT, PRINCIPLES OF OPERATION AND RECENT INNOVATIONS

### Introduction

After a visit to the Yukon alluvial gold fields in the early 1970s, the author decided there had to be a superior machine than the existing methods of treating those deposits. He decided a centrifuge offered advantages and proceeded to research and develop the unit. When the Knelson Concentrator was developed there was very little technical information available on the concept, consequently everything was done by trial and error.

### Concept

Before describing the development stages of the Knelson Concentrator it is necessary to understand the concept of the machine.

Gravel slurry is introduced centrally to the bottom of a ribbed inner cone rotating at a high speed. Centrifugal force causes the first feed to fill the bottom rib with solids and the next higher slightly larger diameter rib and subsequent ones are sequentially filled in a matter of moments. After that all the following feed moves upward as a thin film over the conical surface of the sand filled ribs and out. Compaction of solids trapped in the ribs of the cone is prevented by the injection of water through a series of graduated perforations in the cone wall, and so the trapped solids are fluidised.

If there are any high specific gravity particles (e.g. free gold) in the film of feed slurry that is passing over the fluidised solids trapped in the ribs of the cone, then they will penetrate the fluidised bed under the enhanced gravity situation and displace a lower specific gravity particle of the same volume that is trapped in the rib.

This concentration process continues "trading" light for heavy particles thereby yielding an enriched concentrate.

### Development

The first unit (Refer Figure 1) was designed with-

- (a) An inner cone slope of 30°.
- (b) 50 mm deep by 50 mm spaced rings.

<sup>1</sup> President, Knelson International Sales Inc., Langley, B.C. Canada.

<sup>2</sup> Manager - Alluvial Projects, Metana Minerals N.L., Belmont, W.A., Australia.

- (c) Back pressure water holes drilled straight.
- (d) An outer bowl of cylindrical shape.

The limitations of this design soon became apparent after testing. There was an imbalance in the rings (Refer detail in Figure 1) due to the variation of material thickness in the ring, which in turn made uniform fluidization within the ring difficult.

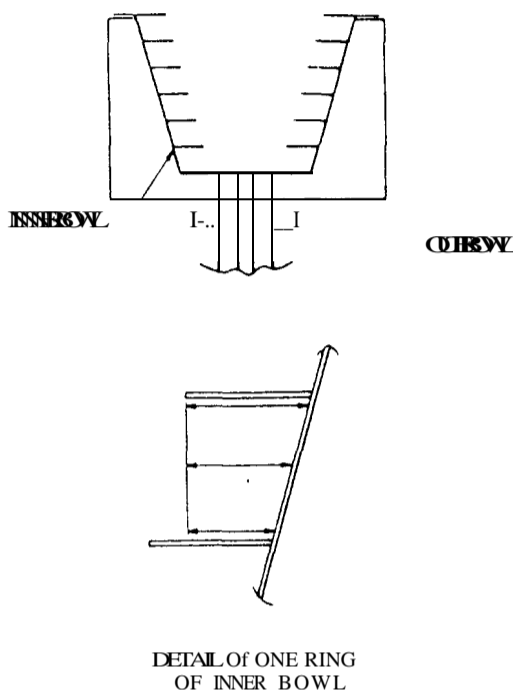

FIG. 1. - First Bowl Design

The second unit (Refer Figure 2) was designed with:-

- (a) A cylindrical shaped inner bowl
- (b) Increasing ring depth from the bottom to the top to form a cone shape.

The purpose of this design was to overcome the above problem, make construction easier and retain a greater volume of concentrate. Early testing with small batches on a small machine indicated the design would work, however, when a larger machine was built another problem became apparent. The water pressure required to fluidise the bottom rings is much greater than the top rings. Consequently the bottom rings became totally compacted.

The third unit (Refer Figure 3) was designed with:-

- (a) A stepped inner cone bowl.
- (b) Tangential injection of back pressure water.
- (c) A conical shaped outer bowl.

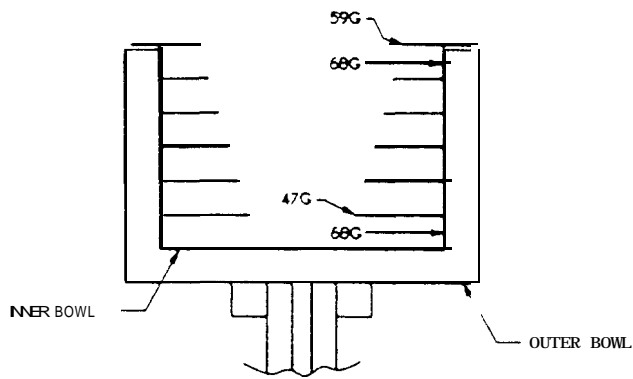

FIG. 2. - Second Bowl Design

The stepped design bowl gave a vertical back wall and all the rings the same depth, which resulted in uniform fluidization of particles within the rings. Tangential injection of back pressure water in the opposite direction to bowl rotation increases turbulence within the rings, with resulting increase of high specific gravity particle capture. An added benefit of tangential injection is the ease of concentrate clean out. After machine shut down the back pressure water is briefly turned on to sluice the concentrates to the bottom of the bowl. Clean up time is around five minutes. (Refer Figure 4)

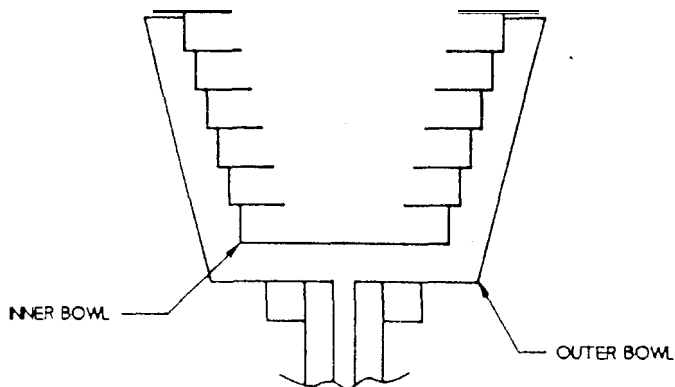

FIG. 3. -Third Bowl Design

The fourth and latest unit (Refer Figure 5) was designed with-

- (a) a wedge shaped profile to the inner bowl rings
- (b) the inner bowl rings moulded in polyurethane to a conical stainless steel casing.

The development of a wedge profile for the inner bowl rings resulted from the observation that there was non uniform concentration of material in the square designed rings. (Refer Figure 6). There was a greater concentration of material at the back wall of the ring due to the differential in G forces, which in turn resulted in areas of non turbulence within the ring. (Refer Figure 7). This problem was overcome by redesigning the rib profile (Refer Figure 8) to eliminate the dead areas. Fortunately the new design lent itself to moulding in polyurethane with the resulting benefits of:-

- (a) Superior Fluidization.
- (b) Superior concentration.

- (c) Less chance of ring compaction.
- (d) Ability to mould rings.
- (e) Much greater bowl life due to abrasion resistance of polyurethane.

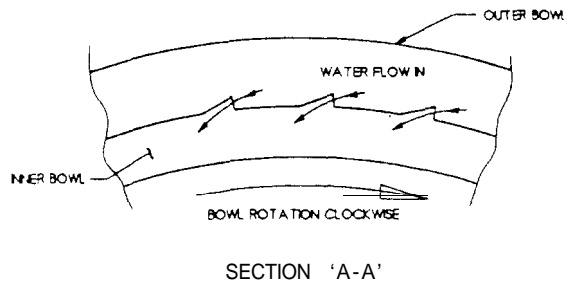
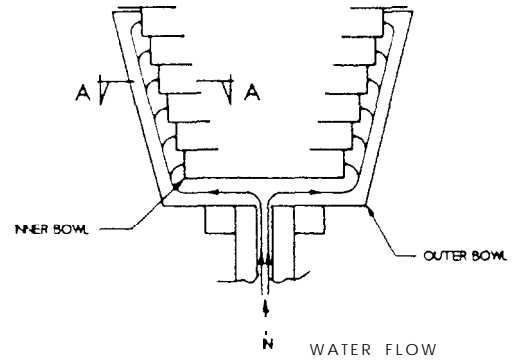

FIG. 4. Back Pressure Water Flow

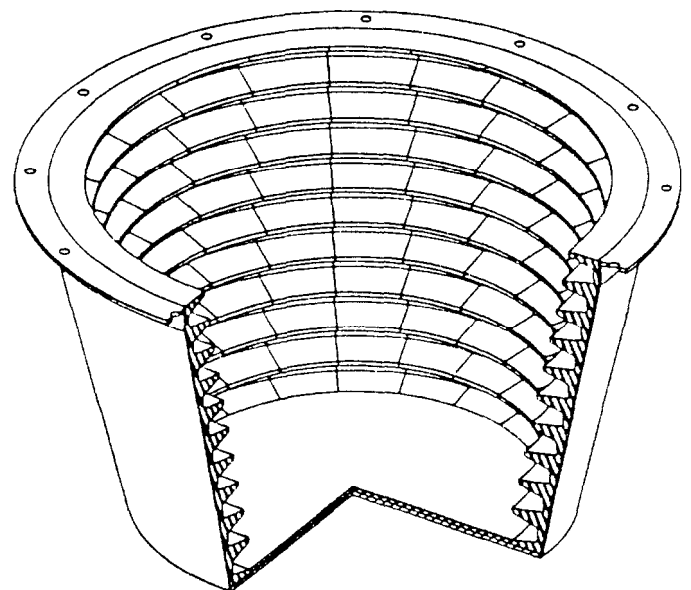

FIG. 5. Present Bowl Design

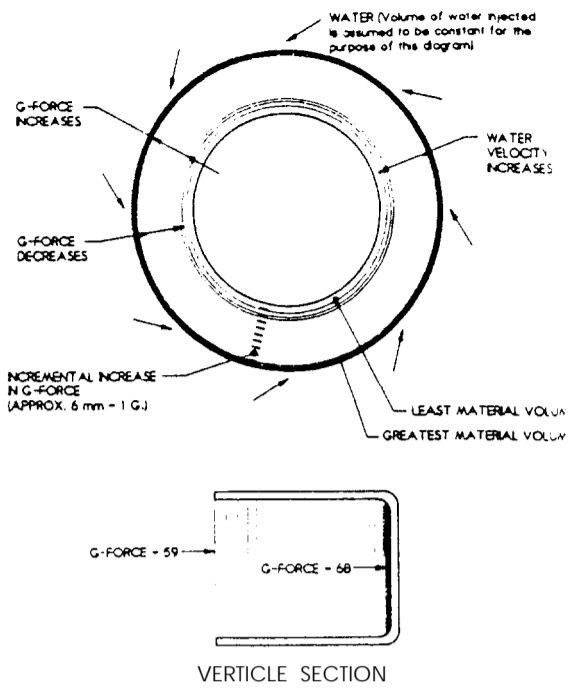

FIG. 6. Relation of G-Force-Water-Material

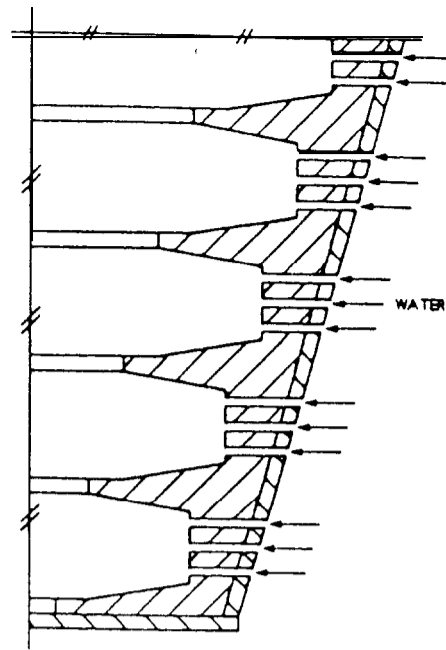

FIG. 8. - Bowl of Present Design

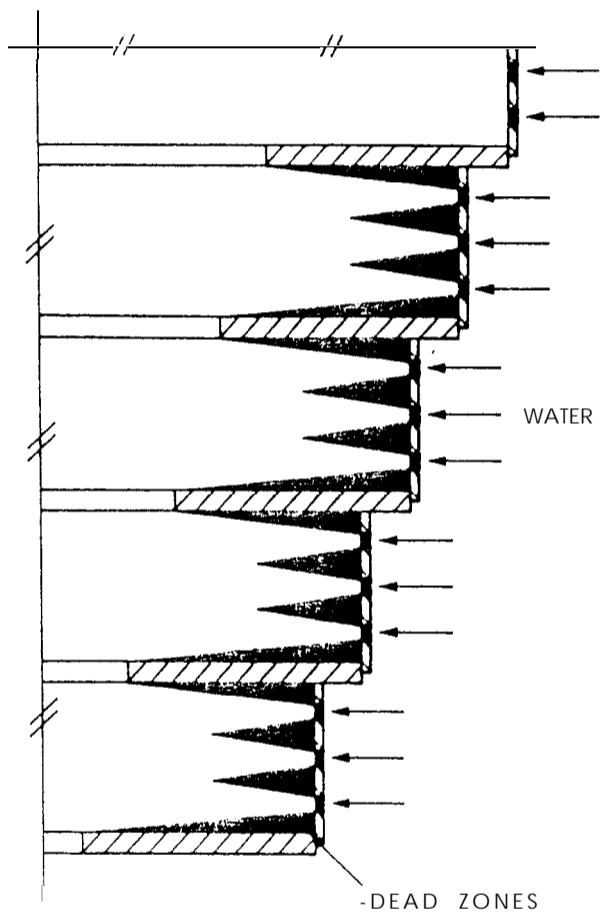

FIG. 7. - Bowl Profile of Third Design

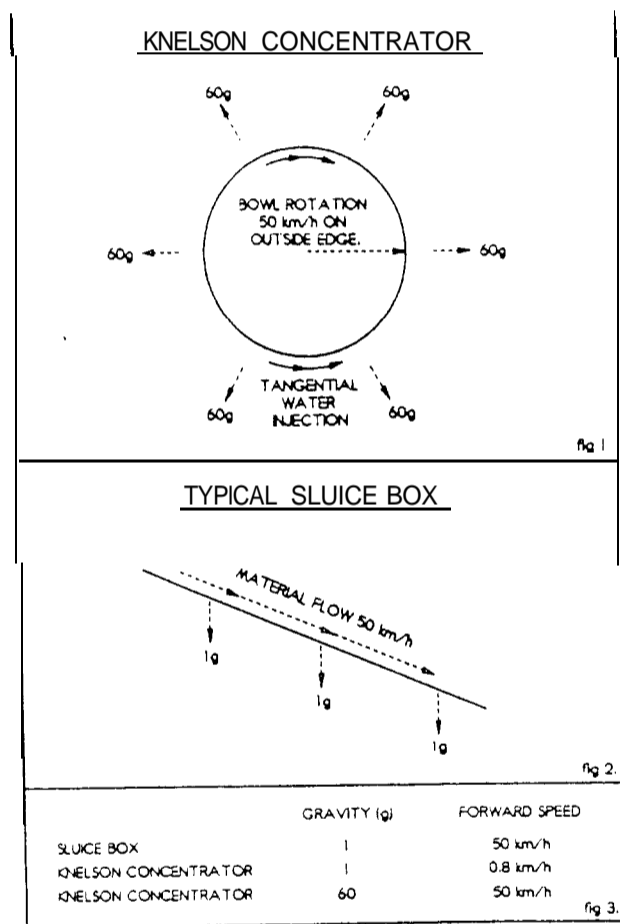

FIG. 9. - Knelson Concentrator

## Basic Theory

A 30" Knelson Concentrator rotates at 400 rev./min. which provides an average peripheral speed of 50km/hr and this generates a centrifugal force equivalent to 60 G's,

Figure 9 compares this with a typical sluice box where the flow may be 50 km/hr but the concentrating force is only 1 G.

Certainly all particles in a Knelson Concentrator are subject to 60 G's just as all particles in a sluice are subject to 1 G, however, the differential in gravitational force between high and low specific gravity particles is enhanced 60 times in a Knelson Concentrator when compared with the same differential in a sluice.

This is a general statement since the bottom ring of a 30" Knelson Concentrator generates about 45 to 47 G's and the G force increases as a particle moves up the conical surface to the top ring where it becomes 59 G's at the surface and about 68 G's in the root of the ring.

## ECONOMIC APPLICATION IN LOW GRADE ALLUVIAL GOLD DEPOSITS

### Introduction

Metana Minerals N.L., a Perth based gold mining company, first became involved in alluvial gold mining at the township of Nullagine in the Pilbara region of Western Australia.

A treatment plant consisting of a trommel - jig gravity circuit was commissioned in 1983 and 18,000 fine ounces of gold was produced from 1 million loose cubic metres (LCM) of ore at an average recovery grade of 0.56 gms/LCM. The Nullagine ore was of a sandy nature with very few recovery problems.

Due to the success of this operation and the experience gained Metana decided to pursue an ongoing interest in alluvial gold mining and an opportunity arose in the Howley region of the Northern Territory.

### Howley Operation

In August 1986 a trommel-jig treatment plant with a flow sheet as per Figure 10 was commissioned at the Old Howley mining centre.

Initial testwork estimated gold recoveries should be about 0.4 gms/LCM but actual recoveries varied in the range of 0.25 to 0.3 gms/LCM.

Recovery losses were caused by:-

- Failure of the tailings water to settle and hence the return water to the plant was extremely slimy.
- Clay balls forming within the trommel and failing to break up. Fine gold is locked within the clay balls which float over the jigs and into the tailings dam.
- Clay balls being ejected with dirty oversize from the trommel

An endeavour to clean up the tailings water to an acceptable level for return using flocculants was successful, however, the costs were prohibitive. Even with clean water gold recoveries were poor due to the failure of the clay balls generated in the trommel to break up.

During the flocculant trials both the head feed and tailings discharge were sampled and the gold sized. (Refer Figure 11). This showed there was not a very large variation in the head feed and tailings fractions. One would have expected a far greater loss

of the minus 250 micron fraction in the tailings. Due to the uniformity of the losses it was concluded that gold was being lost in the clay. (Refer Figure 10 for sampling locations. A for head and B for tailings.)

Many ways of improving recovery were investigated. The dirty oversize from the trommel was improved to an acceptable level by the introduction of high pressure water spray nozzles.

The next plan was to introduce extra jig cells to the circuit to try to reduce gold losses, however, this did not come about due to a chance meeting with Byron Knelson.

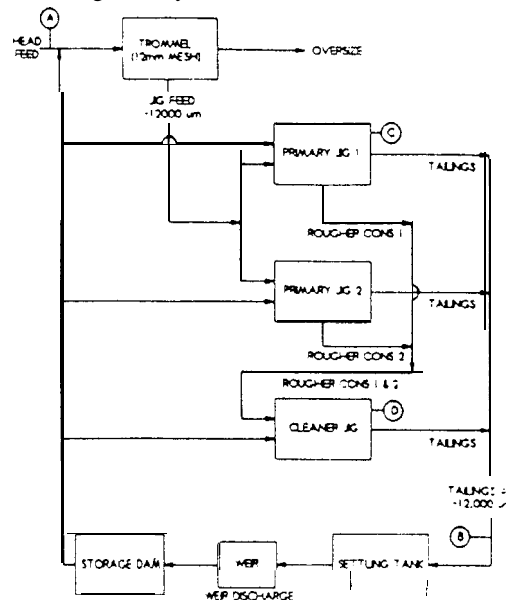

FIG 10- Flow Sheet Trommel-Jig treatment plant before introduction of Knelson Concentrators.

### 7.5" Knelson Concentrator Trials

Following the Darwin Mining Exposition in May 1988 the 7.5" Knelson Concentrator on display was moved to Howley for demonstration and remained there for a few weeks for trials.

The initial demonstration proved what was known, that the jigs were losing gold. What became evident, however, was complete absence of clay balls from the tailings of the concentrator. These tests were conducted on bleed offs at points C and D on Figure 10.

This stimulated considerable interest and it was decided to rent a production size 30" Knelson Concentrator to test for gold losses in the tailings.

### 30" Knelson Concentrator Trials

Before the jigs were disconnected a parcel of approximately 5,000 LCM of tailings was reprocessed back through the trommel jig plant returning an extraction grade of approximately 0.25 gms/LCM. This was done not only for comparative purposes but also so there would be no discussion about benefits of possible breakdown of clay balls in the tailings dam.

On 27 October 1988 the jigs were bypassed and tailings from the same locality were processed through the 30" Knelson Concentrator in a plant layout as shown in Figure 12. It was operated this way until 25 November 1988 during which time 10,224 LCM of tailings were processed returning an outstanding extraction grade of 0.73 gms/LCM. Refer Figure 13.

In order to determine the Knelson Concentrator performance

| HEAD FEED SIZING RESULTS |           |       |      |      |       |       |
|--------------------------|-----------|-------|------|------|-------|-------|
| FRACTION                 | MICRONS   | +3350 | +850 | +250 | +38   | -38   |
| SAMPLE 1                 | DIST Au % | 3.1   | 5.6  | 10.7 | 64.4  | 16.2  |
| SAMPLE 2                 | DIST Au % | 2.8   | 17.3 | 5.5  | 36.2  | 38.3  |
| SAMPLE 3                 | DIST Au % | 43.7  | 8.3  | 6.2  | 15.9  | 25.8  |
| SAMPLE 4                 | DIST Au % | 11.1  | 6.1  | 12.6 | 36.9  | 33.3  |
| SAMPLE 5                 | DIST Au % | 13.6  | 12.0 | 15.7 | 23.0  | 35.6  |
| SAMPLE 6                 | DIST Au % | 4.4   | 1.0  | 2.9  | 81.2  | 10.5  |
| AVERAGE DIST Au %        |           | 13.1  | 8.38 | 8.93 | 42.93 | 26.61 |

| TAILS DISCHARGE SIZING RESULTS |         |       |       |      |       |      |
|--------------------------------|---------|-------|-------|------|-------|------|
| FRACTION                       | MICRONS | +3350 | +850  | +250 | +38   | -38  |
| SAMPLE 1                       | DZTA %  | 3.5   | 7.6   | 1.6  | 1.5   | 85.8 |
| SAMPLE 2                       | JIG     | 0.0   | 31.1  | 12.4 | 29.6  | 268  |
| SAMPLE 3                       | DIST    | 16.5  | 20.9  | 15.0 | 40.2  | 73   |
| AVERAGE DIST Au %              |         | 6.6   | 19.86 | 9.6  | 23.76 | 39%  |

FIG. 11. Summary Metallurgical Laboratory Testwork Sizing Analysis

on raw ore the same plant layout was then trialled on two low grade stockpiles. One stock pile which had averaged 0.12 gms/LCM through the original trommel-jig plant produced an average 0.34 gms/LCM through the trommel-concentrator plant. The other stock pile which had averaged 0.18 gms/LCM through the trommel-jig plant averaged 0.5 gms/LCM through the trommel-concentrator plant.

It was obvious from these trials that Knelson Concentrators were out performing jigs with this particular ore, hence it was decided to include them in the plant layout.

Firstly a tailings retreatment plant as described in Figure 14 was established.

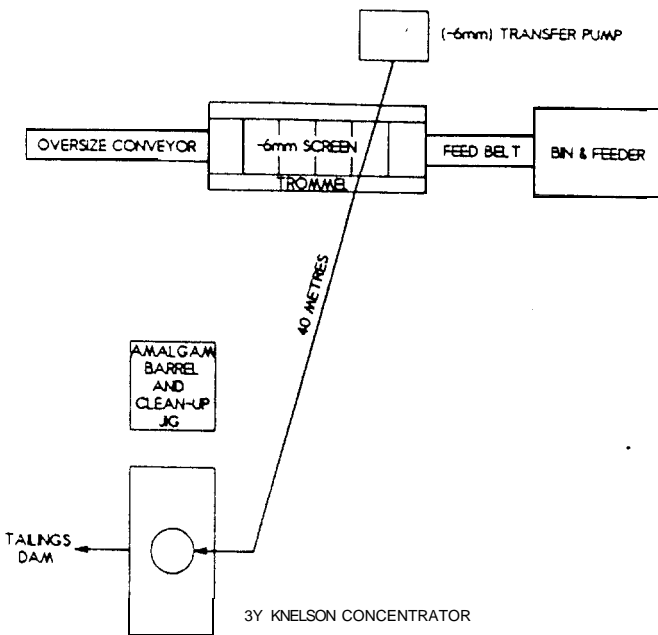

FIG. 12. - Metana Minerals N.L. Howley Tailings Testwork Plant

| DATE         | LCM'S TREATED  | AMALGUM (gms) | AU FINE (gms) | FINE (ozs) | AVE GRADE gms/LCM |
|--------------|----------------|---------------|---------------|------------|-------------------|
| 27th Oct '88 | 93             |               |               |            |                   |
| 28th         | 108            |               |               |            |                   |
| 29th         | 138            | 458           |               |            |                   |
| 31st         | 102            | 559           |               |            |                   |
| 1st Nov '88  | 183            | 400           |               |            |                   |
| 2nd          | 135            | 474           |               |            |                   |
| 3rd          | 162            | 643           |               |            |                   |
| 4th          | 252            | 412           |               |            |                   |
| TOTAL        | 1173           | 2946          | 1447.193      | 46.53      | 1.233             |
| 5            | 258            |               |               |            |                   |
| 6            | 87             | 506           |               |            |                   |
| 7            | 435            | 930           |               |            |                   |
| 8th          | 492            | 1288          |               |            |                   |
| 9th          | 4              |               |               |            |                   |
| 12th         | 428            | 408           |               |            |                   |
| 13th         | 150 gms 10 gms | 534           |               | 0314       |                   |
| 13th         |                | 190           |               |            |                   |
| TOTAL        | 3048           | 4669          | 2293.6        | 73.749     | 0.752             |
|              |                | RETORT 2742.6 |               |            |                   |
| 14th         | 564            | 460           |               |            |                   |
| 15th         | 546            | 414           |               |            |                   |
| 16th         |                | 820           |               |            |                   |
| 17th         | 603            | 583           |               |            |                   |
| 18th         | 588            | 779           |               |            |                   |
| 19th         | 279            | 270           |               |            |                   |
| 20th         | 219            | 603           |               |            |                   |
| TOTAL        | 3399           | 3929          | 1940.2        | 62.38      | 0.57              |
| 21st         | 585            | 1172          | 578.73        |            | 0.994             |
| 22nd         | 469            | 498           | 358.00        |            | 0.732             |
| 23rd         | 396            | 573           | 245.91        |            | 0.62              |
| 24th         | 540            |               | 282.9         | 0523       | 0.523             |
| 25th         | 594            | 652           | 321.95        |            | 0.542             |
| TOTAL        | 2604           | 3620          | 1787.49       | 57.47      | 0.686             |
| 27th Oct '88 |                | 15,164        | 7,468.549     | 240.14     | 0.73              |
| 25th Nov '88 | 10,224         |               |               |            |                   |

Extraction from re-treatment of tailings trommel oversize by itself is approximately 0.314 fine gms/LCM  
Jig tailings are currently being treated at approximate ratio of 3 jig to 1 trommel tails

FIG. 13. Test work using Knelson concentrators production results jig tailings.

**Current Treatment Plant Design**

The flow sheet and typical layout of plants currently being operated by Metana Minerals N.L. at their Howley operations is described in Figure 15.

Each plant consists of a trommel Knelson Concentrators, jig gravity circuit and amalgamation circuit and is capable of processing 80 - 100 LCM of ore per hour depending upon the nature of the ore.

Ore is fed into a holding bin with a hydraulic variable speed belt feeder. Hence onto a belt conveyor to the trommel. It is important that a steady feed rate be maintained to optimise recovery and avoid gold losses, which would result from erratic feeding.

The trommel produces two screened products-

- (a) Minus 6 mm is split equally between the three (3) 30" Knelson Concentrators. Each has the capacity to treat approximately 20 LCM/hr. The concentrate drained from the Knelson Concentrators is pumped directly to a storage bin in readiness for amalgamation.
- (b) Plus 6 mm minus 20 mm material is blended with the minus 6 mm tailings from the Knelson Concentrators and pumped to a 4 x 40" cell primary jig. The primary jig concentrate is pumped to a secondary jig and the concentrate from the secondary jig is pumped to the same storage bin for amalgamation.

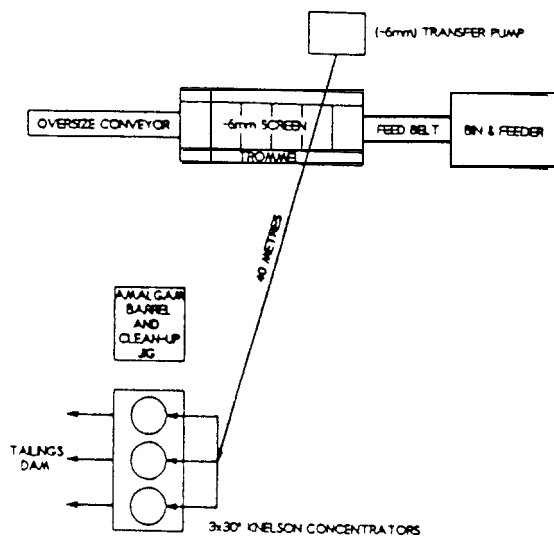

FIG 14. - Metana Minerals N L  
Howley tailings re-treatment plant

The plus 20 mm oversize from the trommel is rejected.

### Practical Considerations

If the operating instructions for the Knelson Concentrators are followed, extremely good recoveries will be achieved.

One of the limitations is that they are restricted to the treatment of only minus 6 mm material. This is of no major concern as most placer deposits contain a large percentage of recoverable gold within this size fraction.

There are no strict guidelines for the incorporation of Knelson Concentrators in a particular production circuit as this will be dictated by local circumstances.

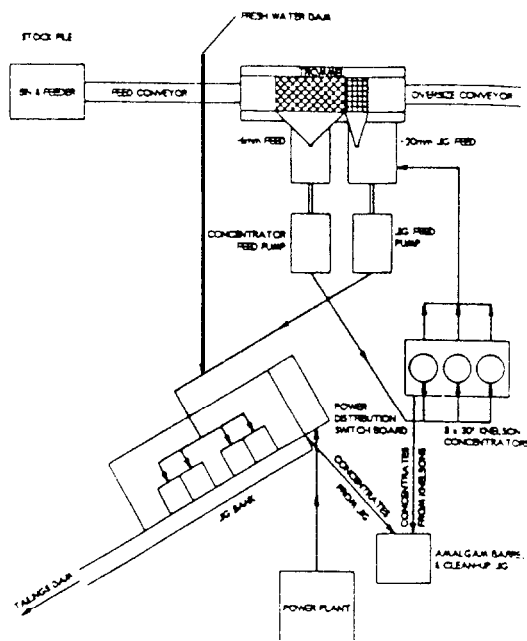

FIG. 15. - Metana Minerals N L  
Treatment plant

| PLANT  | ORE TREATED (LCM) | RECOVERED GRADE (gms/LCM) | GOLD kg | GOLD ozs | ORE AT STOCKPILE (LCM) |
|--|-------------------|---------------------------|---------|----------|------------------------|
| <b>HOWLEY</b>  |                   |                           |         |          |                        |
| No. 1 Plant commissioned 21 August 1986  |                   |                           |         |          |                        |
| No. 2 Plant commissioned 11 May 1987   |                   |                           |         |          |                        |
| Total from both plants at December 1988  |                   |                           |         |          |                        |
|  | 1,014,258         | 0.27                      | 275     | 8,364.31 |                        |
| No. 1 plant (tailings re-treatment), Processing tailings commenced November 1988 using Knelson concentrators. Production to end July 1989. |                   |                           |         |          |                        |
|  | 169,227           | 0.34                      | 57.18   | 1,841.26 |                        |
| <b>No. 3 PANDANUS CREEK</b>  |                   |                           |         |          |                        |
| commissioned 11 September 1989   |                   |                           |         |          |                        |
|  | 53,529            | 0.43                      | 22.8    | 734.24   | 321,434                |

FIG. 16. Production History, Howley Alluvial Project.

Metana Minerals N.L. plants currently use jigs in conjunction with Knelson Concentrators since one particular area being mined has about 20% of its recoverable gold in the plus 6 mm minus 20 mm size fraction. There is no single alluvial treatment process available that will recover more than 80 - 90% of gold in any production situation.

Apart from the jigs being used to collect any gold in the plus 6 mm minus 20 mm range they serve to scavenge any gold from the Knelson Concentrator tailings as well as any gold that is minus 6 mm and carried over to the plus 6 mm minus 20 mm product from the trommel.

In the full production situation the 30" Knelson Concentrators completely break up the clay with the tailings from them being completely free of clay balls.

### Production Results

Figure 16 outlines some of the production history of the Howley Alluvial Project. From August 86 to December 88 an average recovery of gold of 0.27 gms/LCM was achieved from the original trommel-jig plant.

From November 88 to July 89 169.227 LCM of tailing from that plant were reprocessed through the plant as shown in Figure 14 and an average grade of 0.34 gms/LCM gold was recovered.

A new plant as per Figure 15 commissioned at Pandanus Creek, about 1 kilometer from Howley, in September 89 has demonstrated an average recovery of gold of 0.43 gms/LCM and this compares very favourably with the average recovery at the original Howley trommel-jig plant of 0.27 gms/LCM.

### Conclusion

Production costs have not increased since the introduction of Knelson Concentrators but recoveries have increased by about 35%.

Currently there are nine (9) 30" Knelson Concentrators in service. It is regrettable that their capabilities were not discovered two (2) years earlier as this would have saved having to retreat 1 million LCM of tailings.