



KNELSON GRAVITY SOLUTIONS

(A division of Knelson, a corporate partnership)
 19855-98 Avenue, Langley B.C. Canada, V1M 2X5
 Phone: (604)888-4015, Fax: (604)888-4013
 www.knelsongravitysolutions.com, e-Mail: knelson@knelson.com

DATE: MAY 3, 2007

DWG. No. A01527B1

PROSPECTING TRAILER c/w KNELSON CONCENTRATOR MODEL KC-MD7.5 & KC-VS7.5

- | | |
|--|--|
| FEED CAPACITY (MAY VARY DEPENDING ON MATERIAL) | - 0 - 1500 lbs/hr [0 - 680 kg/hr] SOLIDS |
| TYPICAL FLUIDIZATION WATER REQUIREMENT | - 12 - 18 USgpm [45 - 68 Lpm] |
| FEED DENSITY | - 0 - 75% SOLIDS/WEIGHT |
| MAXIMUM TOTAL VOLUMETRIC THROUGHPUT | - 25 USgpm [95 Lpm] |
| FEED SIZE | - 3/16" [4.7mm] MINUS |
| CONCENTRATE VOLUME | - 42 in ³ [0.7 L] |
| CONCENTRATE WEIGHT | - 2.2 - 3.0 lbs [1.0 - 1.4 kg] |
| CONCENTRATOR W/SCREEN NET WEIGHT | - 435 lbs [198 kg] |
| PROSPECTING TRAILER NET WEIGHT | - 2350 lbs [1068 kg] |
| CONCENTRATOR H.P. | - 3/4 (ELECTRIC) |
| VIBRATING SCREEN H.P. | - 1/3 (ELECTRIC) |

- | | |
|---|---|
| APPROXIMATE SHIPPING WEIGHT KC-MD7.5 & KC-VS7.5 | - 596 lbs [271 kg] |
| APPROXIMATE SHIPPING WEIGHT FOR KC-MD7.5 & KC-VS7.5 WITH SPARES | - 620 lbs [281 kg] |
| APPROXIMATE CRATED WEIGHT OF PROSPECTING TRAILER | - 2600 lbs [1180 kg] |
| APPROXIMATE CRATED SHIPPING DIMENSIONS OF KC-MD7.5 & KC-VS7.5 | - LENGTH 125cm x WIDTH 92cm x HEIGHT 155cm |
| APPROXIMATE CRATED SHIPPING DIMENSIONS FOR PROSPECTING TRAILER | - LENGTH 275cm x WIDTH 229cm x HEIGHT 153cm |

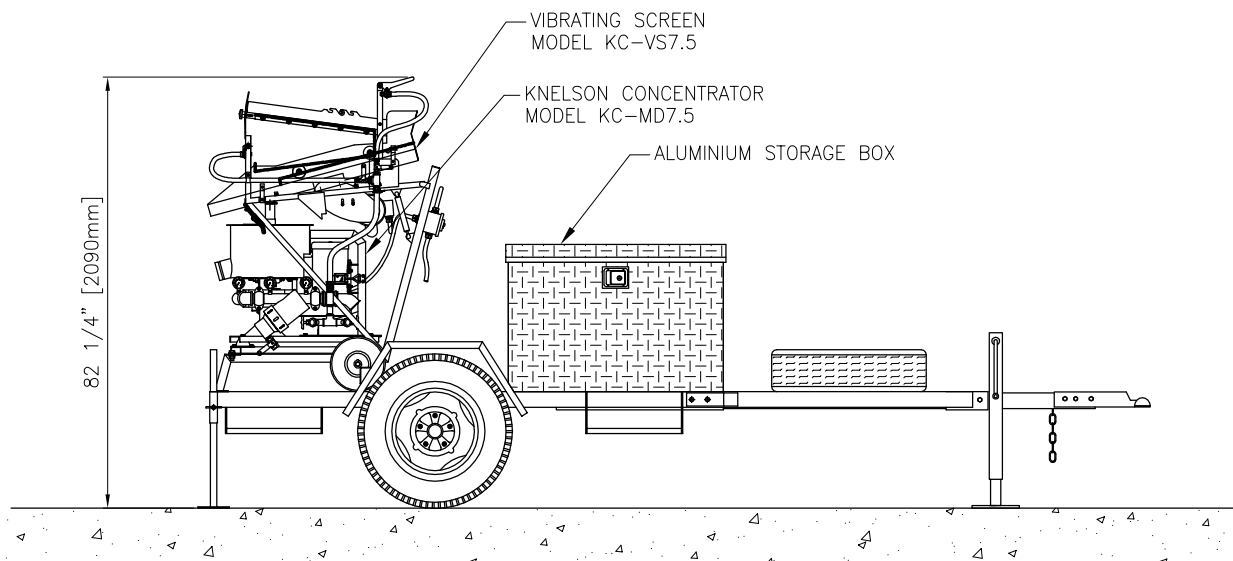
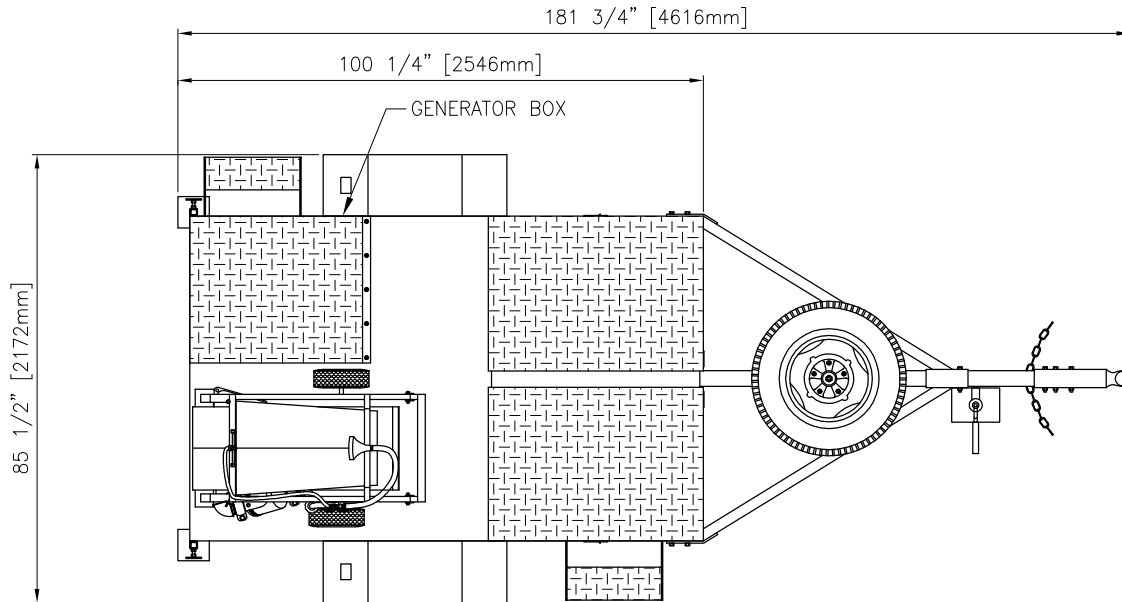

- NOTES:
- 1) DIMENSIONS SUBJECT TO CHANGE WITHOUT NOTICE, AND ARE FOR REFERENCE ONLY.
 - 2) NOT REGISTERED FOR NORTH AMERICAN ROAD USE.